

DOOSAN

Construction Equipment

DL550

Engine Power	SAE J1995, gross 294 kW (394 HP) @ 2,100 rpm
Operational Weight	31,125 kg (68,619 lb)
Bucket Capacity (SAE)	4.5 ~ 8.5 m ³ (5.9 ~ 11.1 yd ³)



DOOSAN DL550 WHEEL LOADER :

A POWERFUL WHEEL LOADER WITH NOVEL FEATURES

DL 550



THE NEW DL550 WHEEL LOADER HAS ALL THE ADVANTAGES OF THE PREVIOUS MODEL, AND NOW OFFERS ADDITIONAL ADDED VALUE TO THE OPERATOR.

The new DL550 was developed with the concept of “providing optimum value to the end user.”

INCREASED PRODUCTION, due to the use of a new generation “Direct Injection” engine and the excellent synchronisation of the drive train with the hydraulics system.

IMPROVED ERGONOMICS, increased comfort and excellent all round visibility ensuring safe and pleasant working conditions.

IMPROVED RELIABILITY, through the use of higher performance new materials, the development of new computer-assisted structural design techniques and by intensive and systematic test programs. All of these combine to increase the life of vital components and reduce operating costs.





PERFORMANCE & PRODUCTIVITY

DL550 features an intelligent, load-sensing hydraulic system. Two variable piston pumps provide the exact flow and pressure required and deliver a powerful, highly effective force, offering superior penetration of the hardest materials. The exceptional drawbar pull at the wheels, is reinforced further by providing Hydraulic differential Lock as standard equipment. The engine offers high power and torque characteristics. As a result, the hydraulic system is able to multi-function with power and speed.



The differential can be automatically engaged, depending on transmission torque, in the first and second gears.

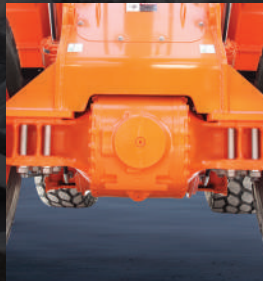



1



2

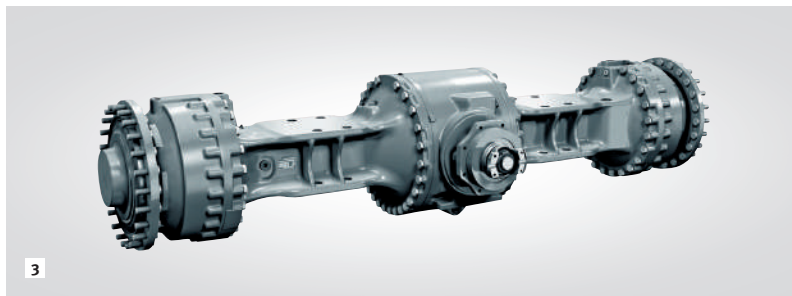

3



4



5



1 SCANIA DC13 ENGINE

Scania DC13 engine is based on electronically controlled unit injectors that gives high torque with good fuel economy and low exhaust emissions

2 FULL AUTO TRANSMISSION

The electronic powershift transmission is particularly smooth and gear ratios perfectly spaced to give optimal speed. That gives comfort at the same time that it delivers excellent traction in every working conditions. Built-in electronic controls enhance productivity and durability. The free wheel stator torque converter improves power train efficiency in load and carry operations which contributes to the improved fuel efficiency.

3 HYDRAULIC DIFFERENTIAL LOCKS

Available standard for DL550. Two modes are available. In manual mode, the operator can use a foot switch to lock the differential completely.

4 HIGH LIFT (OPTIONAL)

As High Lift is equipped besides Standard Lift, customers have further options.

5 HYDRAULIC POWER STEERING

Works with a flow amplifier and priority valve. And the emergency steering system is equipped as an option to secure a safety against a malfunction of steering system during traveling.

HEAVY DUTY AXLE (OPTIONAL)

Even hard working condition heavy duty axle deliver best reliability to customer. Increased brake discs and hub parts give better reliability and cooling efficiency. Heavy duty axle is strong in long hour operation.



DURABILITY & RELIABILITY

Every morning, when the operators commence work, they know that things will go smoothly because Doosan has taken care of it. The product is sold. Operators know that they have significant reserves at hand and that they won't have to push the machine to its limit. The Doosan DL550 wheel loader is designed and built to last. For Doosan, 'reliable' means availability, accessibility and simplicity.

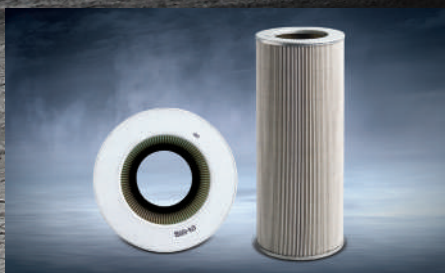

HYDRAULIC OIL RETURN FILTER

The high-efficiency, large-capacity return filter manufactured with the glass-fiber media can eliminate foreign substances up to 99.5 percent to protect the costly hydraulic equipment and substantially extend the replacement cycle.

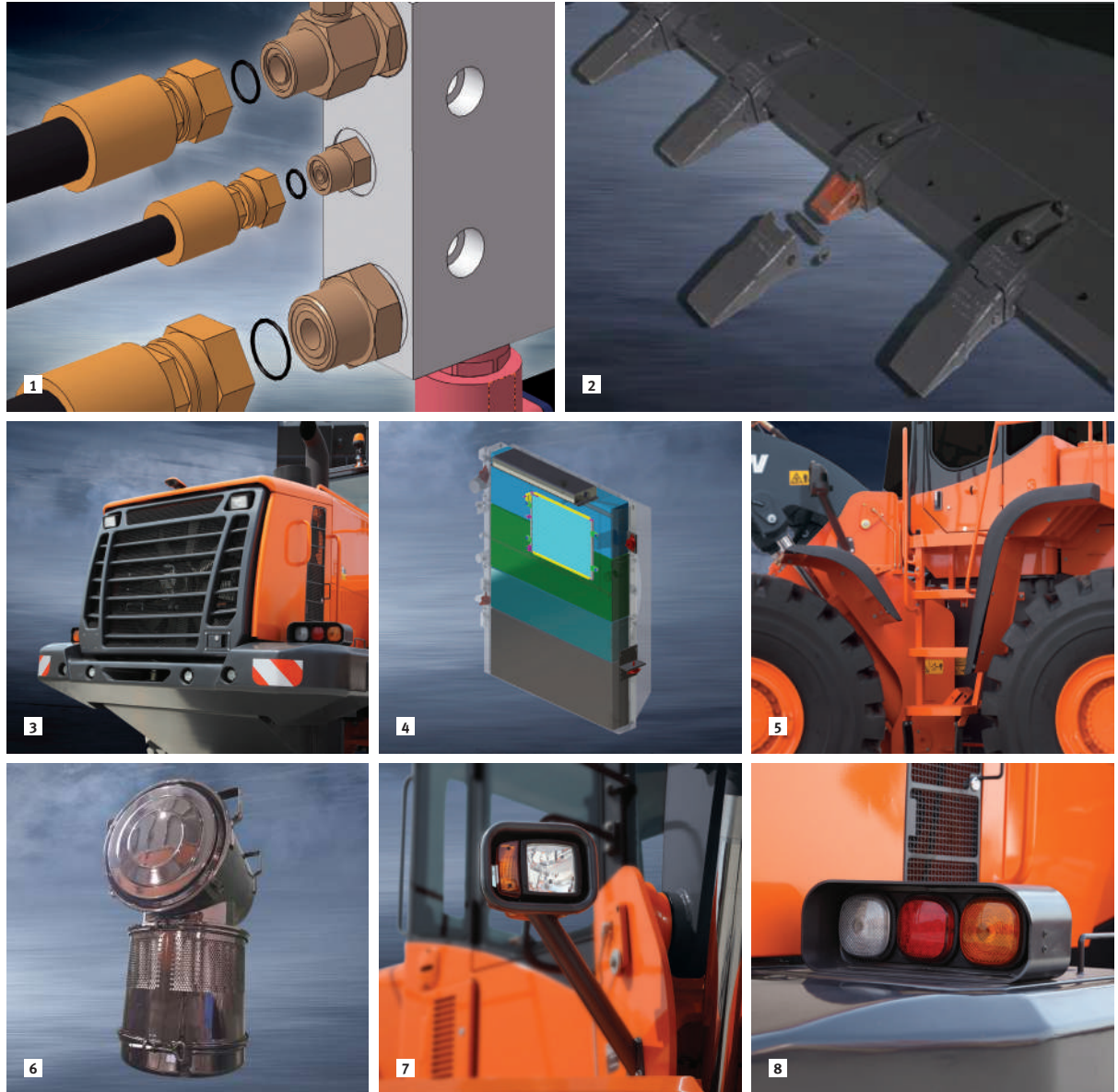

1 ORFS (O-RING FACED SEAL) - ALL PORTS (EVEN IN PILOT LINE AND LOW PRESSURE LINE)

2 2-PIECE TYPE TOOTH (PIN-ON+BOLT-ON ADAPTER / BUCKET OPTION)

3 RADIATOR GRILL (STEEL STRUCTURE)

4 RUBBER-MOUNTING (FOR RADIATOR : LATERAL 2EA / VERTICAL 2EA)

5 FENDER-RUBBER PROTECTOR (OPTIONAL)

6 HEAVY DUTY PRE-CLEANER (OPTIONAL)

Heavy duty pre-cleaner is far more effective in dusty and dirty operating conditions.

7 FRONT COMBINATION LAMP

With the application of high-grade Hella products, the lamp life has extended much more.

8 REAR COMBINATION LAMP

A semi-permanent lamp life has been secured with the application of LED-type stop and position lamps.



OPERATOR COMFORT

From the beginning, Doosan has had great concern for machine operators. People need to work in a well designed and comfortable environment. The work area is spacious, with several places for storage. The checking and monitoring devices are comprehensive. There is an open view of the work area. For night work, operators are provided with powerful front and rear lighting.



1 COLOUR LCD MONITOR PANEL

The 5.5" TFT LCD panel is suitable for day and night work. The monitor is user-friendly and gives full access to machine settings and maintenance data. Any abnormality is clearly displayed on the screen, allowing you to work safely and confidently with an accurate overview of all conditions.

a GAUGES

Engine coolant and transmission oil temperatures, fuel levels.

b ECO BAR

Informs the operator about the fuel efficiency of the current driving profile.

b AUTO-IDLE

Automatically decreases engine rpm when the controls are not operated.

2 TORQUE CONVERTER LOCK-UP SWITCH (OPTIONAL)

The torque converter lock-up function automatically links the impeller (input side) with the turbine (output side). This provides a mechanical connection between the engine and transmission for direct drive. With no power loss, fuel consumption is reduced and traction force is increased. Unlike most other systems, the Doosan torque converter lock-up is automatically engaged from 2nd to 4th gear, depending on transmission torque.

3 AUTOMATIC LIFT ARM KICK-OUT SWITCH

The boom raise kick-down positions create faster cycle times and can be adjusted from within the cab. An optional "return to dig" position is available.



TAILORED PERFORMANCE FOR MAXIMUM EFFICIENCY

The DL550 allows you to select from 3 different working modes: ECO, Normal and Power. It also features a Power-up function which lets the operator switch the machine into a higher working mode with lower transmission shift intervals by fully applying the acceleration pedal.

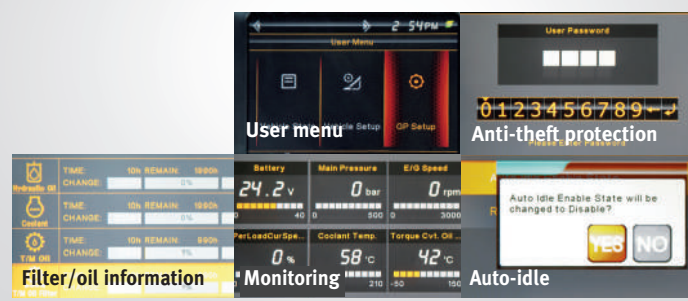

EASY-TO-REACH CONTROL PANEL

All controls are placed to the right, top and front of the operator. They are clearly positioned for comfortable access and grouped by function, enabling safe, confident operation.



JOYSTICK OR FINGERTIP CONTROL

The bucket can be moved using a convenient joystick with an FNR switch and kick-down function. The operator can also choose the option of fingertip control.



TRANSMISSION CUT-OFF

The transmission cut-off function disconnects the driveline from the engine if the brake pedal is engaged. This delivers the full engine power to the hydraulics, speeding up cycle times and boosting fuel efficiency. The brake pressure needed for activation is automatically controlled, depending on speed, pedal angle and transmission resistance.



4 REAR VIEW CAMERA & LCD (OPTIONAL)

A camera provides a clear view of what's happening behind the machine for added safety and peace of mind. The monitor is aligned with the rear mirrors.



5 AIR CONDITIONING & DEFROSTER SYSTEM

Double filtered air cab, air ducts are properly placed all around the cab with proportional sensitive controls and air re-circulation facility. We offer the same comfort as a passenger car.



6 OUTSIDE MIRRORS WITH BUILT-IN HOT WIRES (OPTIONAL)

The hot wires built in the outside mirrors get rid of moisture and frost caused by rain or snow to secure rear fields of vision even in bad weather.

7 WRIST REST

The tilting and telescopic wrist rest allows the operator to work more comfortably.

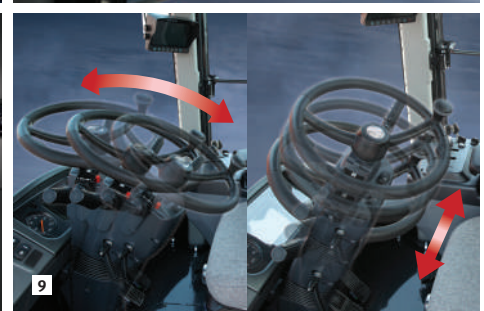

8 SUNVISOR & ROOM MIRROR

9 THE STEERING COLUMN

The steering column features both tilting and telescopic functions.

AIR-SUSPENSION & HEATING SEAT (OPTIONAL)

Now available Air-suspension seats provide more comfort and support for the operator. The built-in hot wires help to rapidly adjust the temperatures to an optimal level to give comfort in the cold winter.





EASY MAINTENANCE

A liquid crystal display conveys information to the operator relative to the ZF transmission. At the same time, it reports the nature of a problem (if one exists). When servicing the loader, a specialised apparatus can be used to adjust the clutch disks to compensate for their wear. Additionally, by connecting a laptop computer, a complete transmission diagnostic can be performed.



CENTRAL JOINTS

The central joints of the machine are particularly robust. The attachment points are positioned to withstand bending and torsion forces. A large amount of space has been left to allow easy access to internal components.



TRANSMISSION & ENGINE DIAGNOSIS

The transmission and engine can be diagnosed using a laptop computer to interface with the diagnostic system.



SWING OUT COOLING FAN

Our fan assembly has been designed with the one touch swing out mechanism and cleaning the radiator core is very easy.

* Option spec info is included to the images contained in this material and may not be the same with the actual specs.

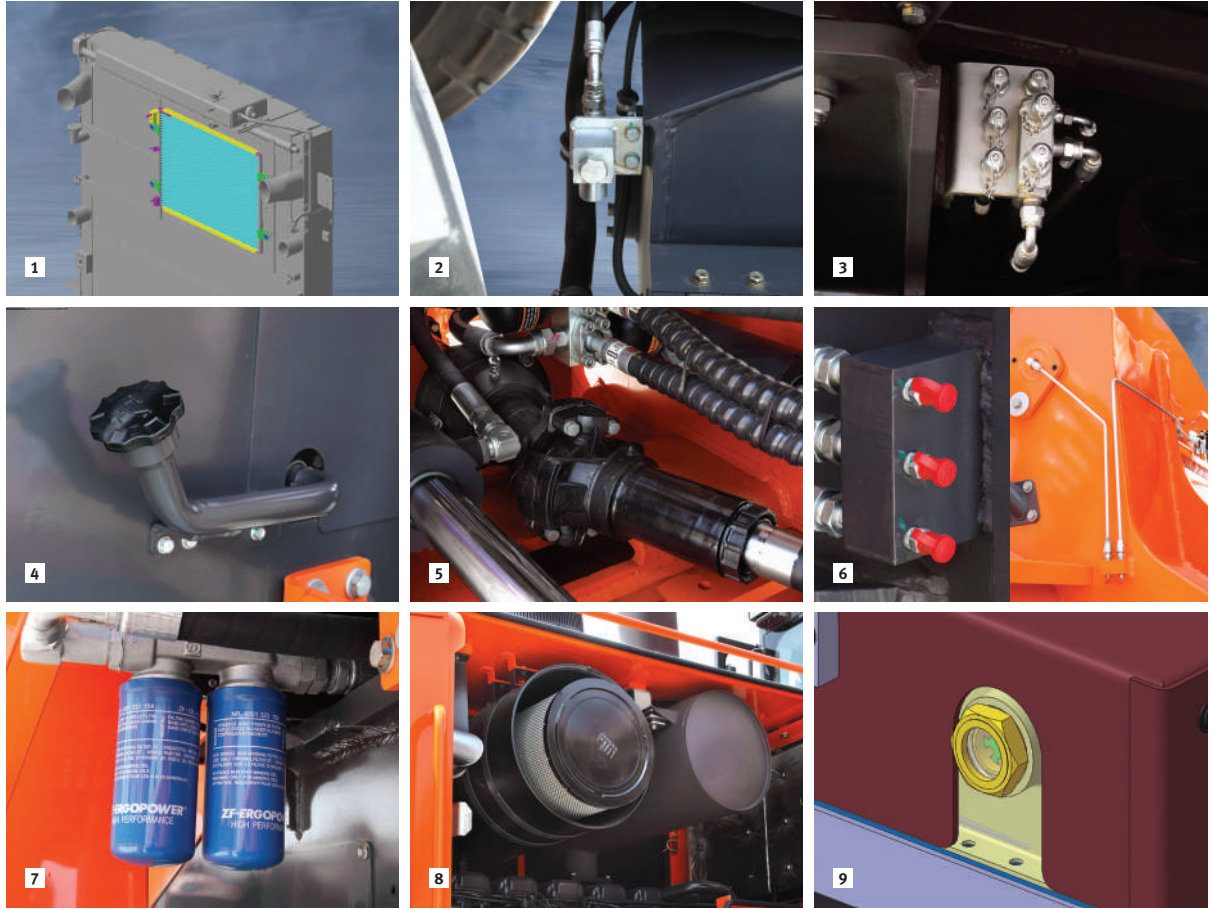

1 IMPROVED AIR CONDENSER

Optimized air condenser position for cooling & maintenance.

2 REMOTE ENGINE OIL & COOLANT DRAIN

Remote drain valves have been installed in an easily accessible location for convenient draining of fluids. (Coolant - Right, Engine oil - Left)

3 CENTRAL REMOTE HYDRAULIC PRESSURE CHECK PORT

The centralized remote hydraulic check ports allow main, steering, brake charge, pilot, load-sensing signal and transmission clutch pressures to be checked at a convenient central location.

4 CONVENIENT TRANSMISSION OIL FILLING

The oil filler pipe is located near the articulation joint for easy access.

5 PROPELLER SHAFT

A protective cover has been installed to protect the oil seal from dust, foreign objects and premature wear.

6 REMOTE GREASING LUBRICATION PORTS

The front pins can be lubricated from the outside of the machine without crawling under the machine or in awkward positions through the lubrication ports.

7 TRANSMISSION FILTER

The transmission filters are within easy reach and like the rest of the machine's service components, can be checked from ground level.

8 AIR-CLEANER FILTER

The high capacity air cleaner eliminates harmful particles from the air and extends the life of the engine and replacement intervals.

9 SIGHT GAUGES

Well-located, yet easily visible sight gauges for the hydraulic oil and radiator coolant allow easy daily checks while reducing the risk of contaminants entering the systems.



TELEMATICS SERVICE (OPTIONAL)

TELECOMMUNICATIONS

Data flow from machine to web



TELEMATICS SERVICE TERMINAL

Telematics Service terminal is installed to machine / connected to EPOS™



TELECOMMUNICATION

GPS, EPOS™ data is sent to designated server by GSM, Satellite telecommunication

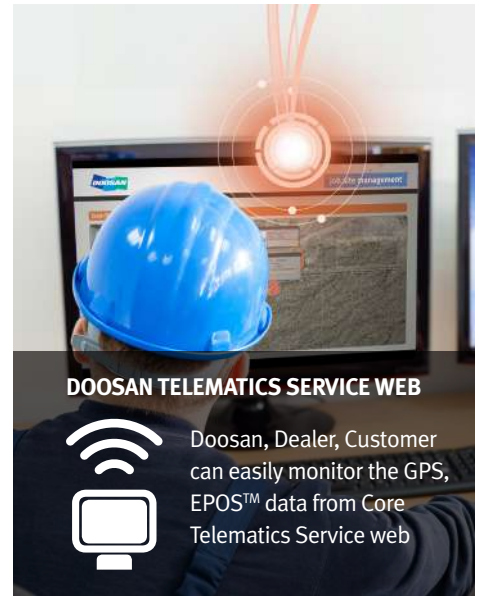

DOOSAN TELEMATICS SERVICE WEB

Doosan, Dealer, Customer can easily monitor the GPS, EPOS™ data from Core Telematics Service web

FUNCTIONS

Doosan Telematics Service provides various functions to support your great performance

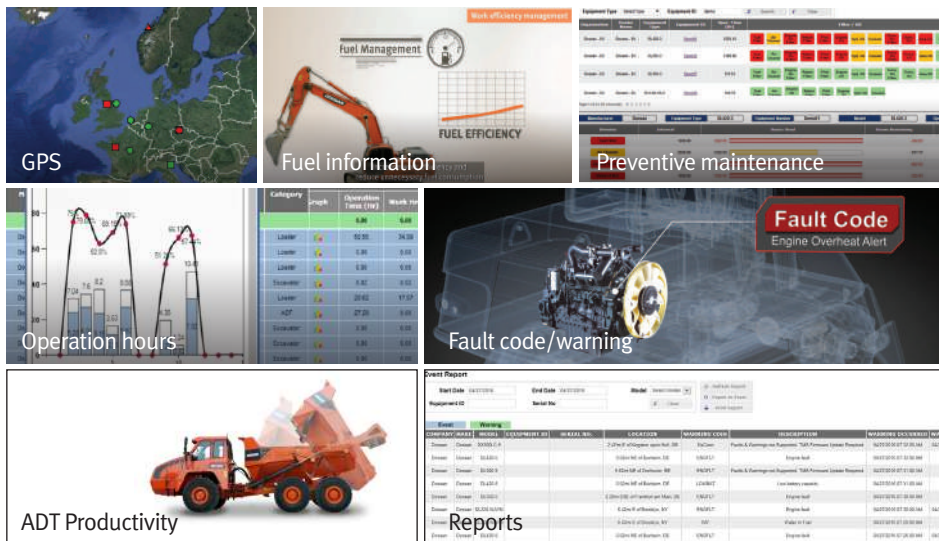

GPS

Fuel information

Preventive maintenance

Operation hours

Fault code/warning

ADT Productivity

TELEMATICS SERVICE BENEFITS

Doosan and dealer support customers to improve work efficiency with timely and responsive services

Customer

Improve work efficiency

- Timely and preventive service
- Improve operator's skills by comparing work pattern
- Manage fleet more effectively

Dealer

Better service for customers

- Provide better quality of service
- Maintain machine value
- Better understanding of market needs

Doosan

Responsive to customer's voice

- Utilize quality-related field data
- Apply customer's usage profile to developing new machine

	FUNCTION	EXCAVATOR	WHEEL LOADER	ADT
GPS	· Location · Geo-fence	All models	All models	All models
E-mail reports	· Daily, Weekly, Monthly report	All models	All models	All models
Operation hours	· Total operation hours · Operation hours by mode	All models Tier 4 only	All models Tier 4 only	All models
Maintenance parts	· Preventive maintenance by item · replacement cycle	All models	Tier 4 only	All models
Fault code/ Warning	· Fault code · Machine Warnings on Gauge Panel	All models	Tier 4 only	All models
Fuel information	· Fuel level · Fuel consumption	All models Tier 4 only	Tier 4 only	All models
Dump capacity	· Dump tonnage · Count of Work Cycle	N/A	N/A	All models



GLOBAL PARTS NETWORK

GLOBAL PDC (PARTS DISTRIBUTION CENTER) NETWORK

Doosan provides fast and precise worldwide delivery of genuine Doosan parts through its global PDC (parts distribution center) network.

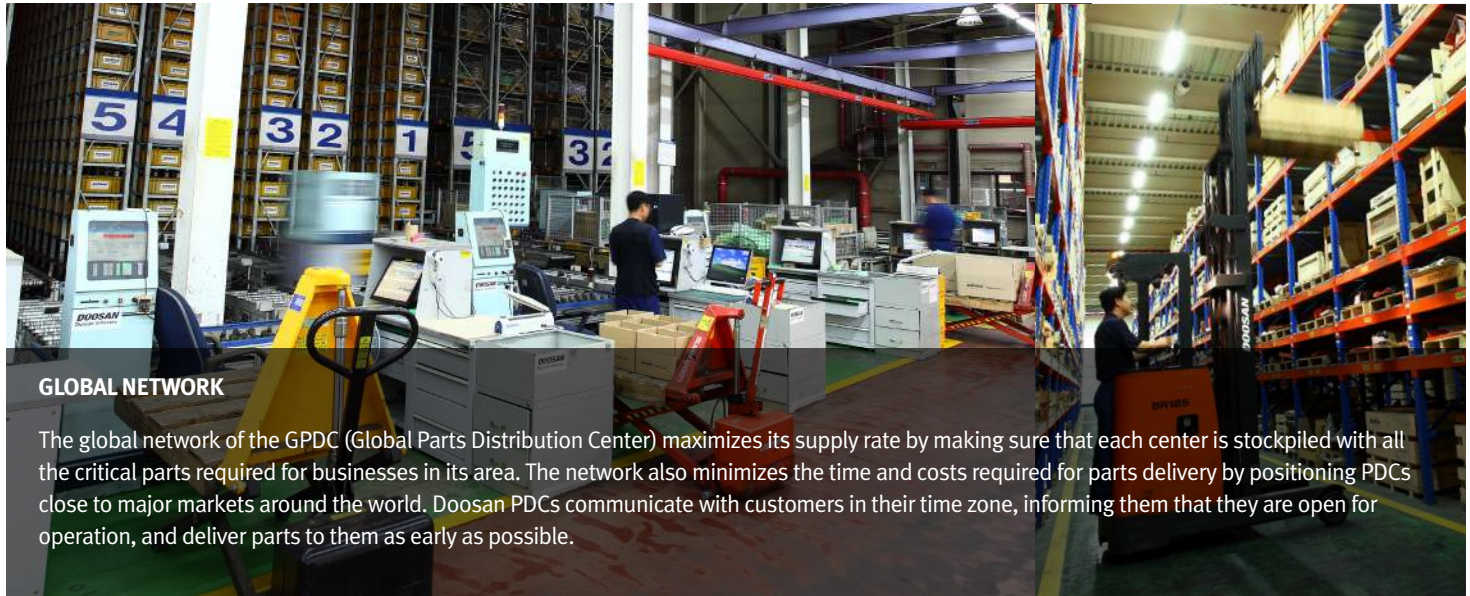

GLOBAL NETWORK

The global network of the GPDC (Global Parts Distribution Center) maximizes its supply rate by making sure that each center is stockpiled with all the critical parts required for businesses in its area. The network also minimizes the time and costs required for parts delivery by positioning PDCs close to major markets around the world. Doosan PDCs communicate with customers in their time zone, informing them that they are open for operation, and deliver parts to them as early as possible.

The Global Parts Distribution Center Network

PDCs had been set up as shown below, including Mother PDC in Ansan, Korea. The seven other PDCs include one in China (Yantai), one in the USA (Chicago), one in Brazil (Campinas), two in Europe (Germany and the UK), one in the Middle East (Dubai), and one in Asia (Singapore).



PDC BENEFIT



Distribution Cost Reduction



Maximum Parts supply rate



Shortest distance/time parts delivery



Real-time service support



Minimum downtime

TECHNICAL SPECIFICATIONS

ENGINE

General description

The high performance Engine Scania DC13 combined a 6 cylinder in-line, high-pressure unit injector fuel injection system with electronically controlled direct injection and turbo charged air to air intercooler offers low fuel consumption and emission.

-GROSS SAE J1995

Rated Power

294 kW (394 HP) @ 2,100 rpm (SAE J1995, gross)

Max. Torque

219.9 kgf.m (2,157N.m) @ 1,200 rpm

Displacement

12,700 cc (775 cu.in)

Bore x stroke

∅ 130 x 160 mm

Wet replaceable cylinder liner

3 stages Air cleaner including a very efficient pre-cleaner, main and safety elements.

Hydraulically driven puller type fan with possibility of adjustment.

Emission

TIER 2/3 (STAGE - II/III)

Battery

System voltage : 24 V

Quantity : 12 V x 2

Capacity (AMP) : 150 Ah

Starter power

24 V / 6.0 kW

Alternator output

28 V / 100 A

AXLES

The front and rear axles with planetary hub reductions are built on the base of very reputed components.

Fitted as standard, the front hydraulic differential locks, ensure the traction is optimal in all circumstances.

Type

Fully floating planetary-type

Differential

Front DHL (100%) / Rear (Open)

Oscillation angle

+/- 10°

Brake

Dual circuit multi-plate wet discs.

Hydraulic actuation with pump and accumulator.

A spring applied and hydraulically released parking brake is mounted on the transmission shaft.

TRANSMISSION

“Full Power Shift” transmission. It can be used in manual or automatic modes.

This transmission is based on components having excellent worldwide reputations. It is equipped with a modulation system allowing soft gear shifting and inversion of travel direction. Safety devices also protect the transmission of bad operations.

The gear and direction shifting is operated by a single lever to the left of the steering wheel. A travel direction control is also mounted on the hydraulic joystick.

With a special electronic device, the transmission can be tested and adjusted easily for optimum performance and efficiently.

The transmission can be de-clutched by the operation of brake pedal to increase the power available to the hydraulic pumps.

A safety device prevents the starting of the engine when not in neutral.

Torque converter

Type : 4 speed, Full auto power-shift, Countershaft, Engine remote mounted with propeller shaft and damper

Stall ratio : 2.598

Travel speed, kph

Forward : 6.5 - 12.4 - 19.7 - *28 - **36 (1 - 2 - 3 - 4 - 5)

Reverse : 6.5 - 12.1 - 19 (1 - 2 - 3)

* : 5 speed w/lock up (option)

** : 4th,5th T/M max speed is 36 km/h

HYDRAULIC SYSTEM

Two load-sensing axial piston pumps with variable displacement.

Main control valve of double acting 2-spool is controlled by standard single lever.

Automatic boom kick out and bucket return to dig. Is standard.

All of hydraulic lines are equipped with special seals (ORFS)

Max flow main

210 ℓ/min (55.5 gal/min)

Working Pressure

275 bars

Pressure of the pilot circuit

30 bars

Filtration capacity on the return line

10 microns

Loading cycles time

Lifting speed (loaded) : 6.3 sec

Dumping speed (loaded) : 1.4 sec

Lowering speed (empty) : 4.2 sec

OPERATOR' CAB

The modular cab allows excellent visibility in all directions. The optimal ventilation is obtained by numerous ventilation outlets. Touch buttons control the air re-circulation air conditioning and heating systems. The air of the cab is filtered.

All necessary information for the operator are centralized in front of him.

The main functions are actuated via switches located on a console at the right of the operator.

Generous storage places are well located. The cab, mounted on viscous element and equipped with an air suspended seat, offers a better comfort for the operator.

Access door : 1

Emergency exits : 2

The cab conforms ROPS ISO 3471 and

FOPS : ISO 3449

STEERING

The steering system is a load sensing type with a flow amplifier and a priority valve.

Steering angle

40°

Oil flow

270 ℓ/min

Working pressure

185 bars

Steering cylinders (2)

bore x stroke : 110 x 465 mm

Emergency steering system with hydraulic pump driven by electric motor. (Optional)

LIFTING SYSTEM

The lifting system with two cylinders and Z configuration is designed for the toughest jobs. The breakout force (247 kN with a 5.4m³ bucket) is optimized for work and the bucket movements are fast.

The "Z" form lifting geometry is extremely robust and especially tailored for demanding jobs. Particularly effective in penetrating piles of hard material, it delivers superior breakout force and loader stability. This is achieved with fewer moving parts and reduced stress on components. Performance improves with rapid bucket movements and correct angle positioning in every situation. With greater dumping and lifting speed for the bucket and lift arm, faster cycle times and increased productivity are ensured.

Lifting cylinders (2)

bore x stroke : 190 x 890 mm

Bucket cylinders (1)

bore x stroke : 220 x 610 mm

MAINTENANCE

Maintenance is easy due to excellent access.

The transmission is electronically controlled. An error coding system allows easy diagnosis of the systems and proper intervention.

Engine (oil) - 45 ℓ (11.8 US gal)

Radiator (cooling liquid) - 60 ℓ (15.8 US gal)

Fuel - 522 ℓ (137.9 US gal)

Hydraulic oil - 247 ℓ (65.2 US gal)

Gear box and torque converter - 54 ℓ (14.2 US gal)

Front axle - 50 ℓ (13.2 US gal)

Rear axle - 50 ℓ (13.2 US gal)

OPERATIONAL DATA

Loader type		General purpose						Rock	High lift
Bucket mount		PIN ON	PIN ON	PIN ON	PIN ON	PIN ON	PIN ON	PIN ON	PIN ON
Configuration	Unit	Adapter tooth	Bolt-on edge	Mono tooth	Adapter tooth	Teeth & segments	Bolt-on edge	Adapter tooth	Bolt-on edge
Capacity heaped ISO/SAE	m ³	5.4	5.7	5.0	5.0	5.2	5.2	4.5	5.7
	yd ³	7.1	7.5	6.5	6.5	6.8	6.8	5.9	7.5
Bucket width	B mm	3,405	3,405	3,405	3,405	3,405	3,405	3,400	3,405
	ft in	11'2"	11'2"	11'2"	11'2"	11'2"	11'2"	11'3"	11'2"
Breakout force	kN	260	260	283	283	282	282	266	253
	lbf	58,450	58,450	63,621	63,621	63,396	63,396	59,799	56,877
Static tipping load (straight)	kg	24,680	24,290	24,845	24,865	24,345	24,480	24,025	19,490
	lb	54,410	53,550	54,774	54,818	53,671	53,969	52,966	42,968
Static tipping load (at full turn)	kg	21,790	21,445	21,935	21,955	21,495	21,615	21,210	17,210
	lb	48,039	47,278	48,358	48,402	47,388	47,653	46,760	37,942
Dump height (at 45°) (at fully raised) ¹⁾	H mm	3,285	3,405	3,355	3,380	3,480	3,355	3,330	3,830
	ft in	10'9"	11'2"	11'0"	11'1"	11'5"	11'0"	10'11"	12'7"
Dump reach (at 45°) (at fully raised) ¹⁾	I mm	1,535	1,400	1,460	1,435	1,325	1,460	1,545	1,620
	ft in	5'0"	4'7"	4'10"	4'9"	4'4"	4'9"	5'1"	5'4"
Dump height (at max. dump) (at max. reach) ¹⁾	mm	685	855	785	820	955	785	730	870
	ft in	2'3"	2'10"	2'7"	2'8"	3'2"	2'7"	2'5"	2'10"
Dump reach (at max. dump) (at max. reach) ¹⁾	mm	1,830	1,750	1,790	1,770	1,710	1,790	1,855	2,295
	ft in	6'0"	5'9"	5'10"	5'10"	5'7"	5'10"	6'1"	7'6"
Digging depth	mm	80	80	80	80	80	80	45	205
	ft in	3"	3"	3"	3"	3"	3"	2"	8"
Height at bucket pivot point	J mm	4,795	4,795	4,795	4,795	4,795	4,795	4,795	5,220
	ft in	15'9"	15'9"	15'9"	15'9"	15'9"	15'9"	15'9"	17'2"
Max. tilt angle at carry position	K deg	48	48	48	48	48	48	48	50
Max. tilt angle at fully raised	M deg	67	67	67	67	67	67	67	62
Max. tilt angle on ground	deg	43	43	43	43	43	43	43	43
Max. tilt angle at max. reach	deg	68	68	68	68	68	68	68	62
Max. dump angle at max. reach	deg	68	68	68	68	68	68	68	65
Max. dump angle on ground	deg	79	79	79	79	79	79	79	79
Max. dump angle at fully raised	deg	47	47	47	47	47	47	47	47
External radius at bucket edge	Q mm	7,565	7,515	7,525	7,535	7,485	7,485	7,555	7,790
	ft in	24'10"	24'8"	24'8"	24'9"	24'7"	24'7"	24'9"	25'7"
Overall length	A mm	9,870	9,680	9,760	9,725	9,575	9,760	9,805	10,255
	ft in	32'5"	31'9"	32'0"	31'11"	31'5"	32'0"	32'2"	33'8"
Operating weight	kg	31,125	31,250	30,950	30,995	31,195	31,120	31,280	31,705
	lb	68,619	68,894	68,233	68,332	68,773	68,608	68,961	69,897

1) Measured to the tip of the bucket teeth or bolt on edge with tires 29.5R25VSNLT(L4)

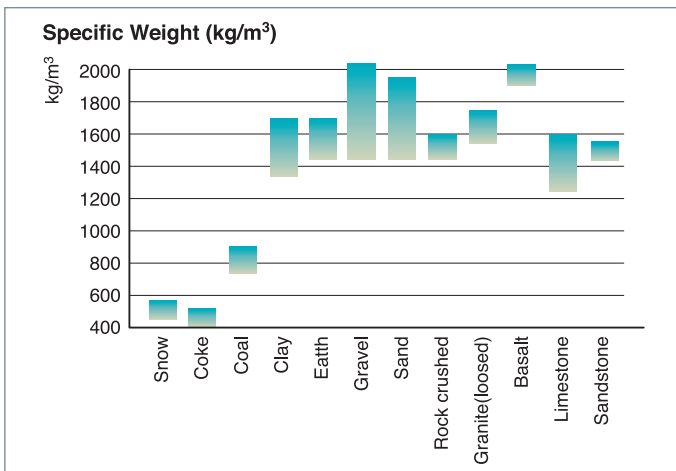

The specific weight of material largely depends on moisture rate, compacting value, percentage of various components etc... This chart is given only for information.

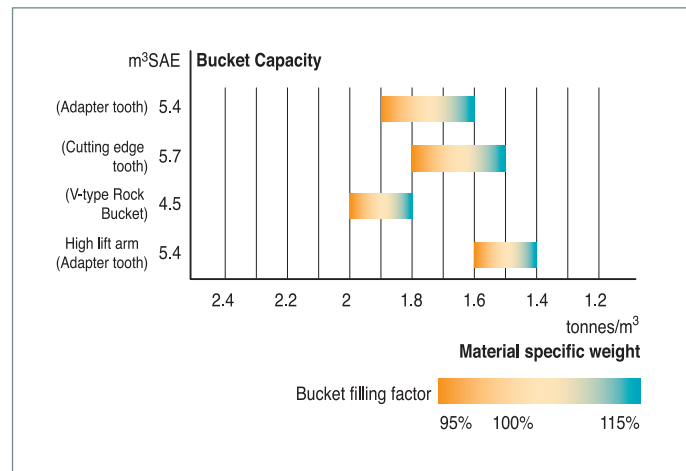

The Bucket filling factor depends also of the nature of material, the working conditions and the operator ability.

DIMENSIONS

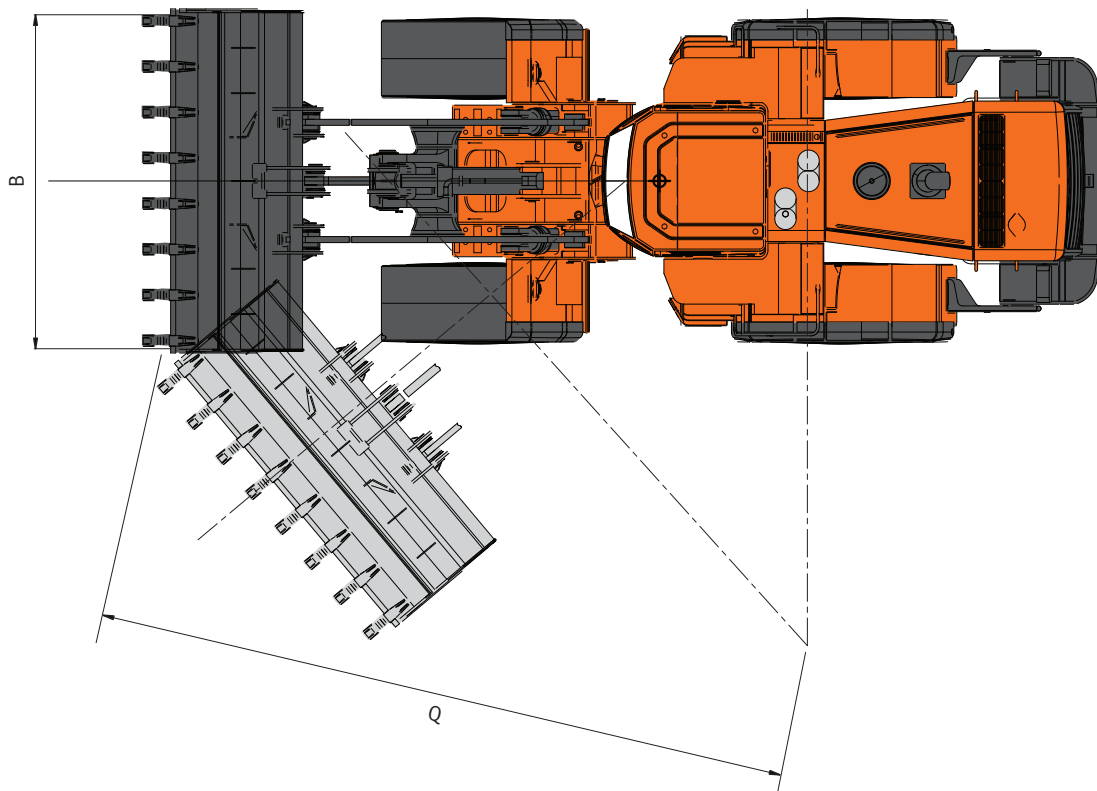
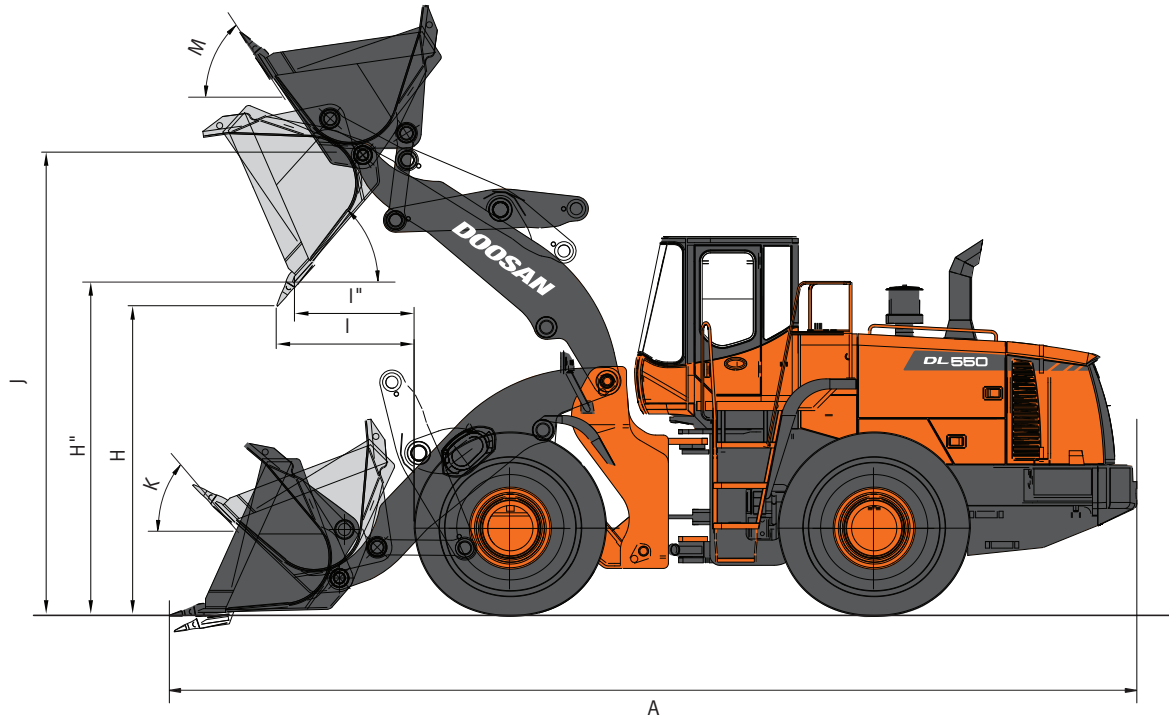

STANDARD AND OPTIONAL EQUIPMENT

STANDARD EQUIPMENT

Engine

- SCANIA DC13 Diesel engine
- Air cleaner - Double element cartridge + Cyclone filtration in prior stage
- Fuel filter - Main fuel filter and fuel pre-filter with water separator
- External drains for engine oil and coolant changes
- Hydraulic radiator fan
- Fuel filler pump

Hydraulic System

- Hydraulic control valve - 2 spool
- Hydraulic main pump - Variable displacement axial piston
- Hydraulic control levers
- Boom kick out - Automatic
- Bucket return to dig - Automatic

Cabin and Interior

- 12V power socket
- Double filtered air cab
- Air conditioner and heater with recirculation function
- Cup holder
- Tinted glasses
- Floor mat
- AM/FM Radio + MP3(USB)
- Windshield washer front and rear
- Windshield wipers front and rear
- Cigarette lighter
- Multiple storage compartments
- Sun visor
- Glass antenna
- Seat - Mechanical suspension
- ROPS cabin - ISO 3471
- FOPS cabin - ISO 3449
- Adjustable steering column
- Rear view mirrors - Interior 2
- Rear view mirrors - Exterior 2

Electrical and lighting

- Battery cut-off switch
- Working light - Front 2 + Rear 4
- Driving light - Low and high beams
- Tail indicators - Stop, reversing lights
- Reversing alarm
- Electric horn
- Alternator - 28V, 100A
- Self-diagnostic system

Linkage

- Z-bar loader linkage

Drivetrain and Brake system

- Gear shift switch - Manual, Auto 1 ↔ 4, Auto 2 ↔ 4
- Kickdown and travelling direction selection
- Starting safety system
- Dual brake circuits with accumulator
- Dual service brake pedals
- Secondary brake system
- Parking brake - Electrical, hydraulic
- Differential - Hydraulic differential locks

Steering system

- Load sensing steering system

External equipment

- Fender

OPTIONAL EQUIPMENT

Some of these optional equipments may be standard in some markets. Some of these optional equipments cannot be available on some markets. You must check with the local Doosan dealer to know about the availability or to release the adaptation following the needs of the application.

Engine

- Fuel filter - Water separator with heater
- Plug heater
- Engine coolant heater
- Air cleaner - Heavy duty pre cleaner

Hydraulic System

- Hydraulic Oil - VG32 Cold Weather
- Hydraulic Oil - VG46 Normal Weather
- Hydraulic Oil - VG68 Tropical Weather
- Hydraulic control valve - 3 spool
- Electrical control valve - 2 spool
- Electrical control valve - 3 spool
- Load isolation system (LIS)
- Hydraulic control levers - Mono
- Hydraulic control levers - FNR
- Hydraulic control levers - Finger tip
- Electrical control levers - Finger tip

Cabin and Interior

- Seat - Air suspension
- Seat - Mechanical suspension with heater
- Seat - Electrical steering
- Camera - Rear view
- Heat wire - Mirror

Electrical and lighting

- License lamp
- Beacon - Rotating
- EMI Filter
- Xenon head lamp

Linkage

- Z-bar high lift loader linkage

Drivetrain and Brake system

- Lock up clutch - 5th Gear
- Axle - Heavy duty

Steering system

- Emergency steering pump
- Electrical steering

External equipment

- Fender - Full fender + rubber protector
- Fender - Rubber protector
- Wheel chocks
- Anti-noise Kit
- Counterweight - 0.4t
- Tool Kit

* Standard specification and options may vary by country.

** Specification is subject to change without prior notice for quality enhancement.

ATTACHMENTS



BUCKETS

General Purpose

Light Material

V-Shape Rock

	Mounting type	Capacity	Width
GENERAL PURPOSE	Direct mount	5.0 / 5.2 / 5.4 / 5.7 m ³	3,404 mm
	Quick coupling	5.4 m ³	3,418 mm
LIGHT MATERIAL	Direct mount	8.0 / 8.5 m ³	3,455 mm
	Quick coupling	8.0 / 8.5 m ³	3,455 mm
V-SHAPE ROCK	Direct mount	4.5 m ³	3,442 mm
	Quick coupling	4.8 / 5.4 m ³	3,418 mm



CONNECTING

Quick Coupler

	Mounting type	Model	Weight
QUICK COUPLER	Quick coupling	DLQC55	800 kg



Pallet Fork



General purpose



Tropical type
Log Grapple



Sorting type

MATERIAL HANDLING

	Model	Length
PALLET FORK	DLPF55	60" / 72" / 78"
	Model	Type
LOG GRAPPLE	DLLG55	General purpose Tropical type Sorting type

Doosan is

Since 1896, Doosan, the oldest company in Korea, has evolved with its people. The company grew up rapidly for last 10 years with reputation. For human-oriented vision, Doosan has been building constructions, energy, machines, infra structures globally. As a global leader of infra structure, Doosan continues its vision to make human-oriented future.

First in Korea, Doosan self-developed excavators in 1985 and continued building versatile construction machines including excavators, wheel loaders, articulated dump trucks to execute its human-oriented philosophy. Doosan became a global leader of heavy construction machine industry by achieving global sales line, producing line, and distribution line. Along with large production bases in Korea, China, USA, Belgium, Czech, Brazil, Doosan has 1400 dealer networks and Doosan is providing reliable products and trusted solutions for your stable business at no risk.

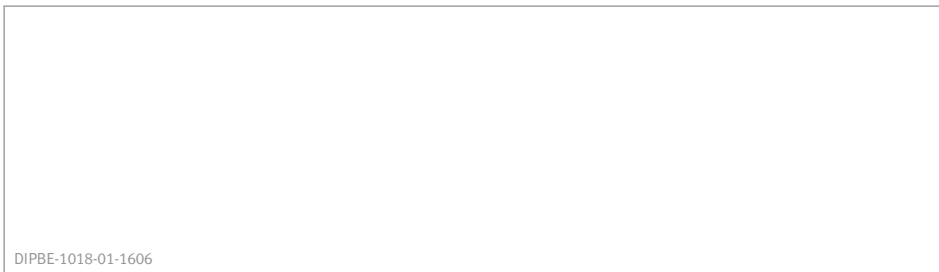

DIPBE-1018-01-1606



Doosan Infracore Korea Office (HQ)
27F, Doosan Tower, 275, Jangchungdan-ro,
Jung-gu, Seoul, Korea(04563)
Tel : 82 2 3398 8114

www.doosaninfracore.com/ce/

Materials and Specifications in the catalogue are subject to change without notice.