



Doosan Infracore
Construction Equipment

DX235LCR

Engine Power : net 124kw(166HP)@1,900rpm
Operational Weight : 24,300kg(53,572 lb)STD
Bucket capacity : 0.51~1.28m³ (0.67~1.67cu.yd)





Hydraulic Excavator DX 235LCR

A New Model Doosan DX 235 LCR
Hydraulic Excavator :

Novel Increased production and improved fuel economy is attributed to the electronic optimization of the hydraulic system and the new generation DOOSAN engine (Tier III Stage). Improved ergonomics increases comfort and excellent all round visibility ensuring a safe and pleasant working environment. Improved reliability is achieved through the use of high performance materials combined with new methods of structural stress analysis, and leads to increased component life expectancy, thus reducing running costs. Reduced maintenance increases the availability and reduces operating costs of the excavator.



DX235LCR



Performance



The performance of the DX 235 LCR has a direct effect on its productivity. Its new "Common Rail" engine and new e-EPOS controlled hydraulic system have combined to create an unbeatable hydraulic excavator, with a cost/performance ratio that makes the DX 235 LCR even more appealing.

DOOSAN DX 235LCR ENGINE

Maker & Model	Doosan DLo6 Diesel Engine
Rated Horse Power	Gross) 175 PS @1900 rpm Net) 168 PS @1900 rpm
Max. Torque	Gross) 78kgf.m@1400rpm Net) 76kgf.m@1400rpm



Reduced Tail Swing Radius

“It can be easily used in the city and tight locations, due to reducing the tail swing radius up to 39%.”



Hydraulic Pump

2 x 220.2 Liter/min @1900 rpm
while a high capacity gear pump improves pilot line efficiency.



Swing Drive

Shocks during rotation are minimized, while increased torque is available to ensure rapid cycles.

Comfort

The work rate of the hydraulic excavator is directly linked to the performance of its operator. DOOSAN designed the DX 235 LCR by putting the operator at the center of the development goals. The result is significant ergonomic value that improves the efficiency and safety of the operator.



Control panel

More space, better visibility, air conditioning, a very comfortable seat... These are all elements that ensure the operator can work for hours and hours in excellent conditions.





Control stand (Telescopic Function)

Comfortable 2-stage sliding seat



1. Control panel

2. Operation modes



Choice of operating modes

- Working mode -Digging mode:for general excavation, loading,lifting...
- Power mode -Standard:uses 85%engine power for all work
-Power:uses 100%engine power for heavy work
-Economic : uses 65% engine power for light work

Control lever

Very precise control of the equipment increases versatility,safety and facilitates tricky operations requiring great precision. Leveling operations and the movement of suspended loads are made easier and safer.

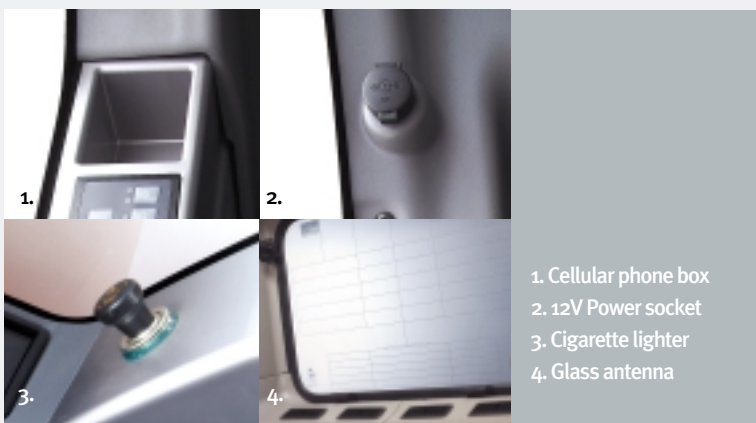

1.

2.

3.

4.

- 1. Cellular phone box
- 2. 12V Power socket
- 3. Cigarette lighter
- 4. Glass antenna

Rear Camera



Reliability & Maintenance

The reliability of a product contributes to its overall lifetime operating costs.

Strengthened Boom

The shape of the boom has been optimized by finite elements design, allowing uniform load distribution throughout the structure.

Arm Assembly

In the arm assembly greater strength has been gained by using cast elements and reinforcement around the bosses to give increased life.

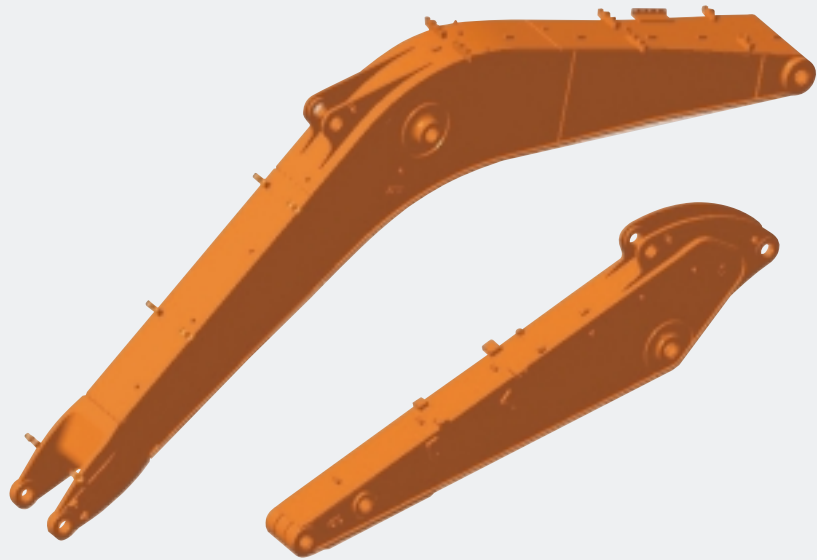

Doosan uses computer- assisted design techniques, highly durable materials and a quality engineered structure. Our research and development engineers test all product under the most extreme conditions. Durability, reliability and product longevity are Doosan's top priorities.

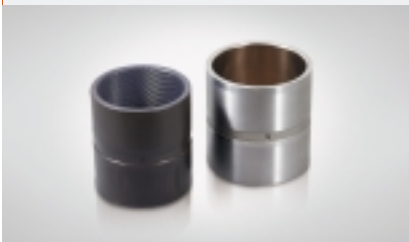

Bushing

A highly lubricated metal is used for the boom pivot in order to increase the lifetime and extend the greasing intervals to 250 hours.



Ultra-hard wear-resistant disc

New materials have been used in order to increase the wear resistance and to increase the service intervals.



X-chassis

The X-chassis frame section has been designed using finite element and 3-dimensional computer simulation



Integrated Track Spring and Idler

The track spring and the idler have been joined directly to achieve high durability and improved maintenance convenience.



Tracks

The chain is composed of self-lubricating sealed links isolated from all external contamination.



Easy maintenance

Easy access to the various radiators and coolers makes cleaning easier. Access to the various parts of the engine is from the top and via side panels.

DOOSAN has developed the DX 235 LCR profitability with end-user in mind. Easy maintenance operations at long intervals increase the availability of the equipment on site.



Engine oil filter

The engine oil filter offers a high level of filtration allowing the oil change interval to be increased to 500 hours.



Hydraulic oil return filter

The protection of the hydraulic system is more effective, using glass fiber filter technology in the main oil return filter.



Air cleaner

The large capacity forced air cleaner removes over 99% of airborne particles, reducing the risk of engine contamination and making the cleaning and cartridge change intervals greater.



Fuel pre-filter

High efficiency fuel filtration is attained by the use of multiple filters, including a fuel pre-filter fitted with a water separator that removes most moisture from the fuel.

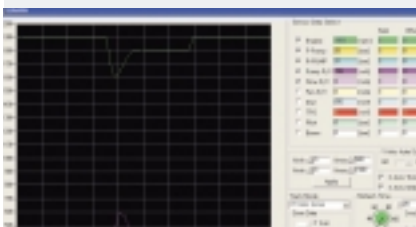

PC Monitoring (DMS)

A PC monitoring function enables connection to the e-EPOS system, allowing various parameters to be checked during maintenance



Convenient Fuse Box

The fuse box is conveniently located in a section of the storage compartment behind the operator's seat providing a clean environment and easy access.

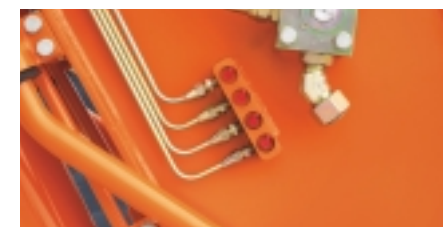

Centralized grease inlets for easy maintenance

The arm grease inlets are grouped for easy access.

Technical Specification

Engine

MODEL

Doosan DLo6
"Common Rail" engine with direct fuel injection and electronic control, 4 valves per cylinder, vertical injectors, water cooled, turbo charged with air to air intercooler. The emission levels are well below the values required for phase III.

NUMBER OF CYLINDERS

6

NOMINAL FLYWHEEL POWER

124kw(166HP)@1900rpm (SAE J1349, net)

MAX TORQUE

78 kgf.m(765 Nm) at 1,400 rpm

PISTON DISPLACEMENT

5,890 cc (359 cu.in)

STARTER

24 V / 4.5 kW

BATTERIES

2 x 12 V / 100 Ah

AIR CLEANER

Double element with auto dust evacuation.

Hydraulic System

The heart of the system is the e-EPOS (Electronic Power Optimizing System). It allows the efficiency of the system to be optimized for all working conditions and minimizes fuel consumption. The new e-EPOS is connected to the engine electronic control via a data transfer link to harmonize the operation of the engine and hydraulics.

- The hydraulic system enables independent or combined operations.
- Cross-sensing pump system for fuel savings.
- Auto deceleration system.
- Two operating modes, two power modes.
- Button control of flow in auxiliary equipment circuits.
- Computer-aided pump power control.

MAIN PUMPS

2 variable displacement axial piston pumps
max flow: 2 x 220.21 /min(2x58 US gpm, 2 x 48 lmp gpm)

PILOT PUMP

Gear pump - max flow: 26.1 /min(6.9 US, 5.7 IMP)

MAXIMUM SYSTEM PRESSURE

Boom/Arm/Bucket - Normal mode: 350kgf/cm² (343bar)
Power mode - 370kgf/cm² (363bar)
Travel - 330 kgf/cm² (324 bar)
Swing - 300 kgf/cm² (294 bar)

Weight

Boom 5,700 mm (18'8") / Arm 2,900 mm (9'6") / Bucket SAE 0.92 m³ (1.20 yd³)

Shoe width (mm)	Operating weight	Ground pressure (kgf/cm ²)
STD. 600 mm	23,700 kg (52,248 lb)	0.50 kgf/cm ² (49 kpa, 7.11 psi)
700 mm	24,000 kg (52,910 lb)	0.43 kgf/cm ² (42 kpa, 6.11 psi)
800 mm	24,300 kg (53,571 lb)	0.38 kgf/cm ² (37 kpa, 5.4 psi)
900 mm	24,600 kg (54,232 lb)	0.34 kgf/cm ² (33 kpa, 4.83 psi)

Hydraulic Cylinders

The piston rods and cylinder bodies are made of high-strength steel. A shock absorbing mechanism is fitted in all cylinders to ensure shock-free operation and extend piston life.

Cylinders	Quantity	Bore x Rod diameter x stroke
Boom	2	130 X 90 X 1,355mm(5.1" X 3.5" X 5'3")
Arm	1	135 X 95 X 1,490mm(5.3" X 3.7" X 5'8")
Bucket	1	120 X 80 X 1,060mm(4.7" X 3.1" X 4'1")

Undercarriage

Chassis are of very robust construction, all welded structures are designed to limit stresses. High-quality material used for durability. Lateral chassis welded and rigidly attached to the undercarriage. Track rollers lubricated for life, idlers and sprockets fitted with floating seals. Tracks shoes made of induction-hardened alloy with triple grouser. Heat-treated connecting pins. Hydraulic track adjuster with shock-absorbing tension mechanism.

NUMBER OF ROLLERS AND TRACK SHOES PER SIDE

upper rollers : 2 / Lower rollers : 9 / Shoes : 49 /
Total Length of Track : 4,445mm

Environment

Noise levels comply with environmental regulations (dynamic values).

SOUND LEVEL GUARANTEE - 103 dB(A)(2000/14/EC)

CAB SOUND LEVEL - 74 dB(A) (ISO 6396)

Bucket

Swing Mechanism

An axial piston motor with two-stage planetary reduction gear is used for the swing. Increased swing torque reduces swing time. Internal induction-hardened gear. Internal gear and pinion immersed in lubricant bath. The swing brake for parking is activated by spring and released hydraulically.

SWING SPEED - 0 to 11.3 rpm

Drive

Each track is driven by an independent axial piston motor through a planetary reduction gearbox. Two levers with control pedals guarantee smooth travel with counterrotation on demand.

TRAVEL SPEED (FAST/SLOW) - 5.8 / 3.1 km/h

DRAWBAR PULL - 11,300 kg / 23,400 lbf

MAXIMUM GRADE - 35. / 70%

Refill Capacities

FUEL TANK - 320 (84.5 US gal)

COOLING SYSTEM (RADIATOR CAPACITY) - 34 (8.9 US gal)

ENGINE OIL - 27 (7.1 US gal)

SWING DRIVE - 5 (1.32 US gal)

TRAVEL DRIVE(EACH) - 3.3 (0.8 US gal)

HYDRAULIC SYSTEM/LEVEL : 230 (60.7 US gal)/130 (34.3 US gal)

Capacity		Width		Weight	Recommendation	
PCSA, heaped	CECE heaped	Without side cutters	Width side cutters		5,700mm (18'8") One-piece Boom	
					2,400mm (7'10") Arm	2,900mm (9'6") Arm
0.51m ³ (0.67 yd ³)	0.47m ³ (0.62 yd ³)	722mm (2'4")	772mm (2'6")	530 kg (1,168 lb)	A	A
0.81m ³ (1.06 yd ³)	0.72m ³ (0.94 yd ³)	1,064mm (3'6")	1,126mm (3'8")	654 kg (1,442 lb)	A	A
0.92m ³ Std.(1.20 yd ³)	0.81m ³ (1.06 yd ³)	1,172mm (3'10")	1,236mm (4'1")	710 kg (1,565 lb)	A	B
1.05m ³ (1.37 yd ³)	0.92m ³ (1.20 yd ³)	1,308mm (4'3")	1,370mm (4'6")	740 kg (1,631 lb)	A	B
1.17m ³ (1.53 yd ³)	1.0m ³ (1.31 yd ³)	1,428mm (4'8")	1,491mm (4'11")	795 kg (1,753 lb)	B	C
1.28m ³ (1.67 yd ³)	1.11m ³ (1.45 yd ³)	1,542mm (5'1")	1,605mm (5'3")	830 kg (1,830 lb)	C	-

A. Suitable for materials with density of 2,000 kg/m³ (3,370 lb/CU · yd) or less

B. Suitable for materials with density of 1,600 kg/m³ (2,700 lb/CU · yd) or less

C. Suitable for materials with density of 1,100 kg/m³ (1,850 lb/CU · yd) or less

Dimensions

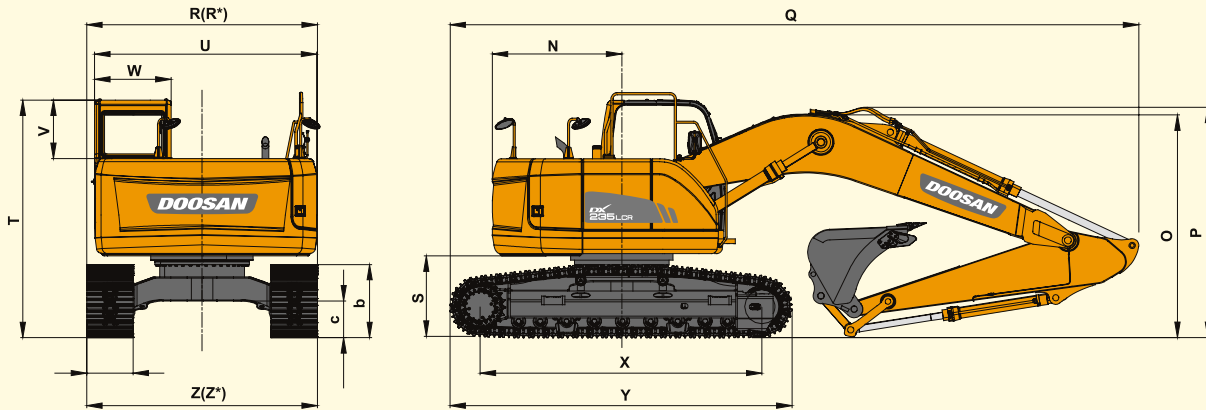

	(mm)		(ONE PIECE) 5700	
BOOM TYPE	(mm)			
ARM TYPE	(mm)		2900	2400
BUCKET TYPE (PCSA)	(m ³)		0.92	1.05
TAIL SWING RADIUS	(mm)	N	1680	-
SHIPPING HEIGHT (BOOM)	(mm)	O	2870	2980
SHIPPING HEIGHT (HOSE)	(mm)	P	2955	3070
SHIPPING LENGTH	(mm)	Q	8955	9010
SHIPPING WIDTH	(mm)	R	2990	-
C/WEIGHT CLEARANCE	(mm)	S	1025	-
HEIGHT OVER CAB.	(mm)	T	3080	-
HOUSE WIDTH	(mm)	U	2870	-
CAB. HEIGHT ABOVE HOUSE	(mm)	V	760	-
CAB. WIDTH	(mm)	W	980	-
TUMBLER DISTANCE	(mm)	X	3650	-
TRACK LENGTH	(mm)	Y	4445	-
UNDERCARRIAGE WIDTH	(mm)	Z	2990	-
SHOE WIDTH	(mm)	a	600	-
TRACK HEIGHT	(mm)	b	947	-
CAR BODY CLEARANCE	(mm)	c	480	-

Working Range

DX235LCR

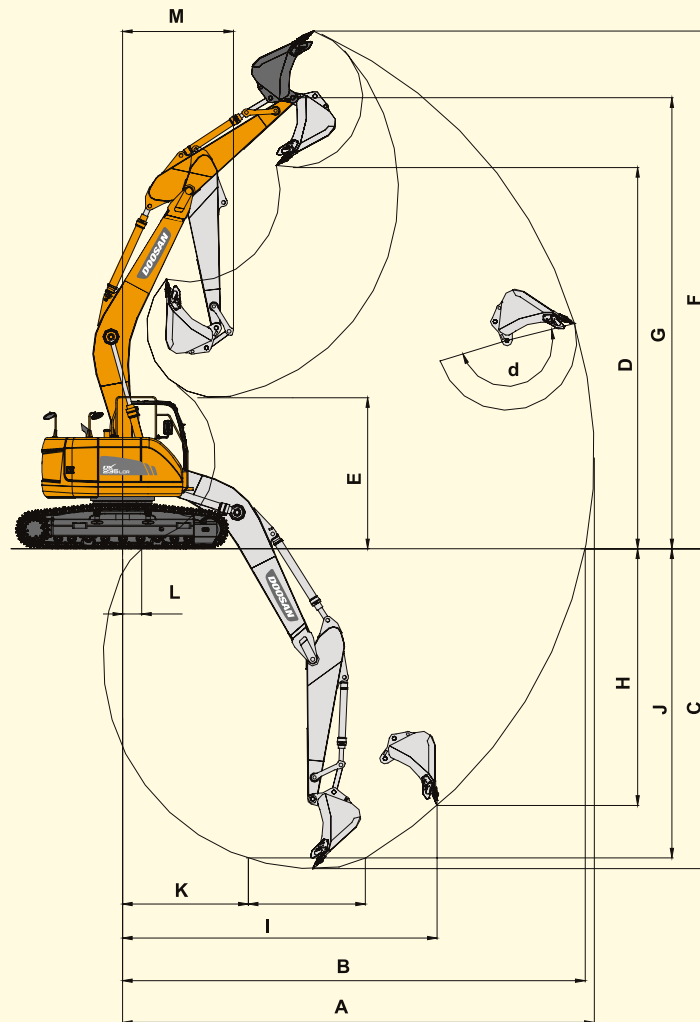

BOOM TYPE (ONE PIECE)	(mm)		(ONE PIECE) 5700	
ARM TYPE	(mm)		2900	2400
BUCKET TYPE (PCSA)	(m ²)		0.92	1.05
MAX. DIGGING REACH	(mm)	A	9820	9415
MAX. DIGGING REACH (GROUND)	(mm)	B	9630	9215
MAX. DIGGING DEPTH	(mm)	C	6670	6170
MAX. LOADING HEIGHT	(mm)	D	7955	7705
MIN. LOADING HEIGHT	(mm)	E	3155	3740
MAX. DIGGING HEIGHT	(mm)	F	10795	10565
MAX. BUCKET PIN HEIGHT	(mm)	G	9405	9160
MAX. VERTICAL WALL DEPTH	(mm)	H	5350	5050
MAX. RADIUS VERTICAL	(mm)	I	6550	6270
MAX. DEPTH TO 8' LINE	(mm)	J	6440	5940
MIN. RADIUS 8' LINE	(mm)	K	2570	2660
MIN. DIGGING REACH	(mm)	L	395	1630
MIN. SWING RADIUS	(mm)	M	2310	2545
BUCKET ANGLE	(deg)	d	177	177

Lifting Capacity

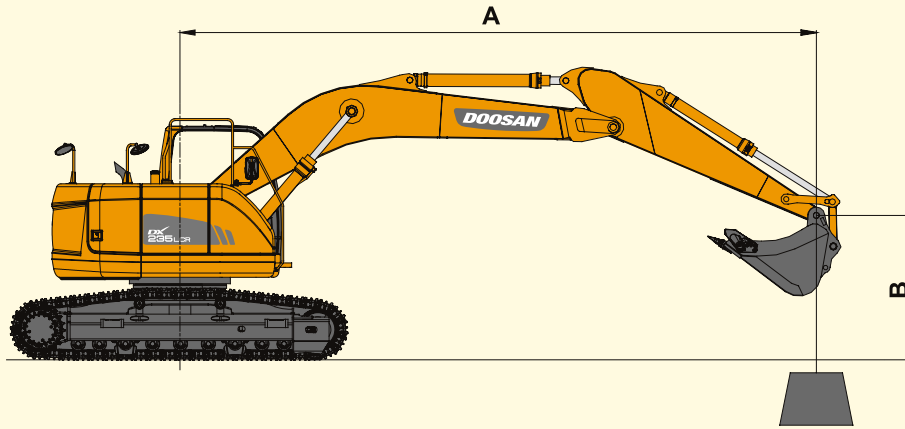

Standard

Boom : 5,700mm(18'8") Arm : 2,900mm(9'6") Bucket : SAE 0.92m³(CECE 0.81 m³) Shoe : 600mm(24")

Metric

Unit : 1,000kg

A(m) B(m)	2		3		4		5		6		7		8		Max. Reach			
	Rating Over Front	Rating Over Side or 360 degree	Rating Over Front	Rating Over Side or 360 degree	Rating Over Front	Rating Over Side or 360 degree	Rating Over Front	Rating Over Side or 360 degree	Rating Over Front	Rating Over Side or 360 degree	Rating Over Front	Rating Over Side or 360 degree	Rating Over Front	Rating Over Side or 360 degree	Rating Over Front	Rating Over Side or 360 degree	A(m)	
8							*4.77*	*4.77*							*3.95	*3.95	5.48	
7							*5.46	*5.46	*4.66	*4.66					*3.75	*3.75	6.43	
6							*5.76	*5.76	*5.61	4.61	*4.06	3.46			*3.69	3.34	7.13	
5					*7.02	*7.02	*6.40	6.14	*5.97	4.48	*5.38	3.39			*3.73	2.88	7.62	
4	*17.47	*17.47	*11.08	*11.08	*8.62	8.49	*7.31	5.84	*6.51	4.30	5.62	3.29			*3.85	2.59	7.96	
3			*15.02	12.62	*10.49	7.86	*8.37	5.51	7.09	4.10	5.48	3.17	4.37	2.49	*4.05	2.40	8.16	
2			*7.98	*7.98	*12.16	7.31	9.31	5.19	6.87	3.91	5.34	3.04	4.29	2.42	4.09	2.30	8.23	
1			*7.79	*7.79	*13.23	6.94	9.02	4.94	6.68	3.74	5.22	2.93	4.22	2.35	4.07	2.26	8.18	
0			*9.50	*9.50	13.15	6.75	8.83	4.78	6.55	3.62	5.13	2.85	4.17	2.30	4.17	2.3	8.00	
-1	*8.70	*8.70	*11.88	11.06	13.06	6.68	8.73	4.69	6.47	3.55	5.08	2.80			4.4	2.43	7.69	
-2	*11.36	*11.36	*14.82	11.15	*12.92	6.69	8.71	4.68	6.45	3.53	5.08	2.80			4.84	2.67	7.23	
-3	*14.30	*14.30	*15.04	11.31	*11.89	6.78	8.77	4.73	6.50	3.58					5.64	3.12	6.58	
-4	*16.51	*16.51	*12.79	11.56	*10.27	6.94	*8.29	4.85							*7.07	4.00	5.68	
-5			*9.50	*9.50	*7.65	7.21									*6.96	6.26	4.37	
-6																		

Feet

Unit : 1,000d

A(ft) B(ft)	10		15		20		25		Max. Reach		
	Rating Over Front	Rating Over Side or 360 degree	Rating Over Front	Rating Over Side or 360 degree	Rating Over Front	Rating Over Side or 360 degree	Rating Over Front	Rating Over Side or 360 degree	Rating Over Front	Rating Over Side or 360 degree	A(ft)
25			*11.95	*11.95					*8.50	*8.50	19.29
20			*12.73	*12.73	*12.13	9.89			*8.14	7.48	23.20
15	*19.97	*19.97	*15.63	15.46	*13.54	9.45	*9.58	6.29	*8.31	6.04	25.53
10	*31.98	27.23	*19.96	14.05	15.25	8.83	10.48	6.02	*8.91	5.31	26.74
5	*17.46	*17.46	23.55	12.78	14.56	8.22	10.15	5.71	8.97	5.01	26.98
0	*21.52	*21.52	22.7	12.07	14.08	7.79	9.91	5.49	9.18	5.08	26.26
-5	*29.95	23.74	22.44	11.86	13.87	7.61			10.14	5.60	24.51
-10	*32.56	24.21	22.63	12.02	13.98	7.71			12.54	6.95	21.47
-15	*24.18	*24.18	*17.34	12.57					*15.58	10.97	16.39
-20											

- RATINGS ARE BASED ON SAE J1097
- LOAD POINT IS THE HOOK ON THE BACK OF THE BUCKET.
- * RATED LOADS ARE BASED ON HYDRAULIC CAPACITY.
- RATED LOADS DO NOT EXCEED 87% OF HYD. CAPACITY OR 75% OF TIPPING CAPACITY.

Rating Over Front
Rating Over Side or 360 degree

Standard and Optional Equipment

DX235LCR

Standard Equipment

HYDRAULIC SYSTEM

- Boom and arm flow regeneration
- Boom and arm holding valves
- Swing anti-rebound valves
- Spare ports(valve)
- One-touch power boost

CABIN & INTERIOR

- Viscous cab mounts
- All weather sound suppressed type cab
- Air conditioner
- Adjustable suspension seat with head rest and adjustable arm rest
- Pull-up type front window and removable lower front window
- Room light
- Intermittent windshield wiper
- Cigarette lighter and ashtray
- Cup holder
- Hot & Cool box
- 7" Wide LCD color monitor panel
- Engine speed(RPM) control dial
- AM/FM radio
- Remote radio ON/OFF switch
- 12V spare powers socket
- Serial communication port for laptop PC interface
- Joystick lever with 3 switches
- Sunvisor
- Sun roof
- Wiper

SAFETY

- Large handrails and step
- Punched metal anti-slip plates
- Seat belt
- Hydraulic safety lock lever
- Safety glass
- Hammer for emergency escape
- Right and left rearview mirrors
- Travel alarm
- Emergency engine stop

UNDERCARRIAGE

- Hydraulic track adjuster
- Track guards
- Greased and sealed track link

OTHERS

- Double element air cleaner
- Fuel pre-filter
- Dust screen for radiator/oil cooler
- Engine overheat prevention system
- Engine restart prevention system
- Self-diagnostic system
- Alternator(24V, 60 amps)
- Electric horn
- Halogen working lights(frame mounted 1, boom mounted 2)

Optional Equipment

Some of the optional equipment may be standard in some markets. Some of the optional equipment will not be available in some markets. You must check with the local DOOSAN dealer about the availability or to release the adaptation following the needs of the applications.

SAFETY

- Boom and arm hose rupture protection valve
- Overload warning device
- Cabin Top/Front guard(ISO 10262, FOGS standard)
- Travel & swing alarm
- Rotation beacon
- Lamp on counter weight

CABIN & INTERIOR

- Air suspension seat
- MP3/CD player or cassette player
- Rain shield
- 4 front + 2 rear lamps

UNDERCARRIAGE

- 600mm/700mm/800mm/900mm shoe

OTHERS

- Piping for crusher
- Piping for quick clamp
- Breaker filter
- Fuel heater
- Fuel filler pump
- Rear viewer Camera



www.doosaninfracore.com

The illustrations do not necessary show the product in standard version. All products and equipment are not available in all markets. Materials and specifications are subject to change without prior notice.